

THIS DRAWING IS UNPUBLISHED. RELEASED FOR PUBLICATION
 © COPYRIGHT BY TYCO ELECTRONICS CORPORATION. ALL RIGHTS RESERVED.

LOC	DIST	REVISIONS					
		P	LTR	DESCRIPTION	DATE	DWN	APVD
G	14		D1	REV PER ECR 06-014599	16JUN06	JR	MS

AMP WIRE RANGE	Listed FILE E13288	LR7189 Certified
12-10 AWG SOLID OR STRANDED	12-10 AWG P/N 31772 ONLY	12-10 AWG P/N 31772 ONLY

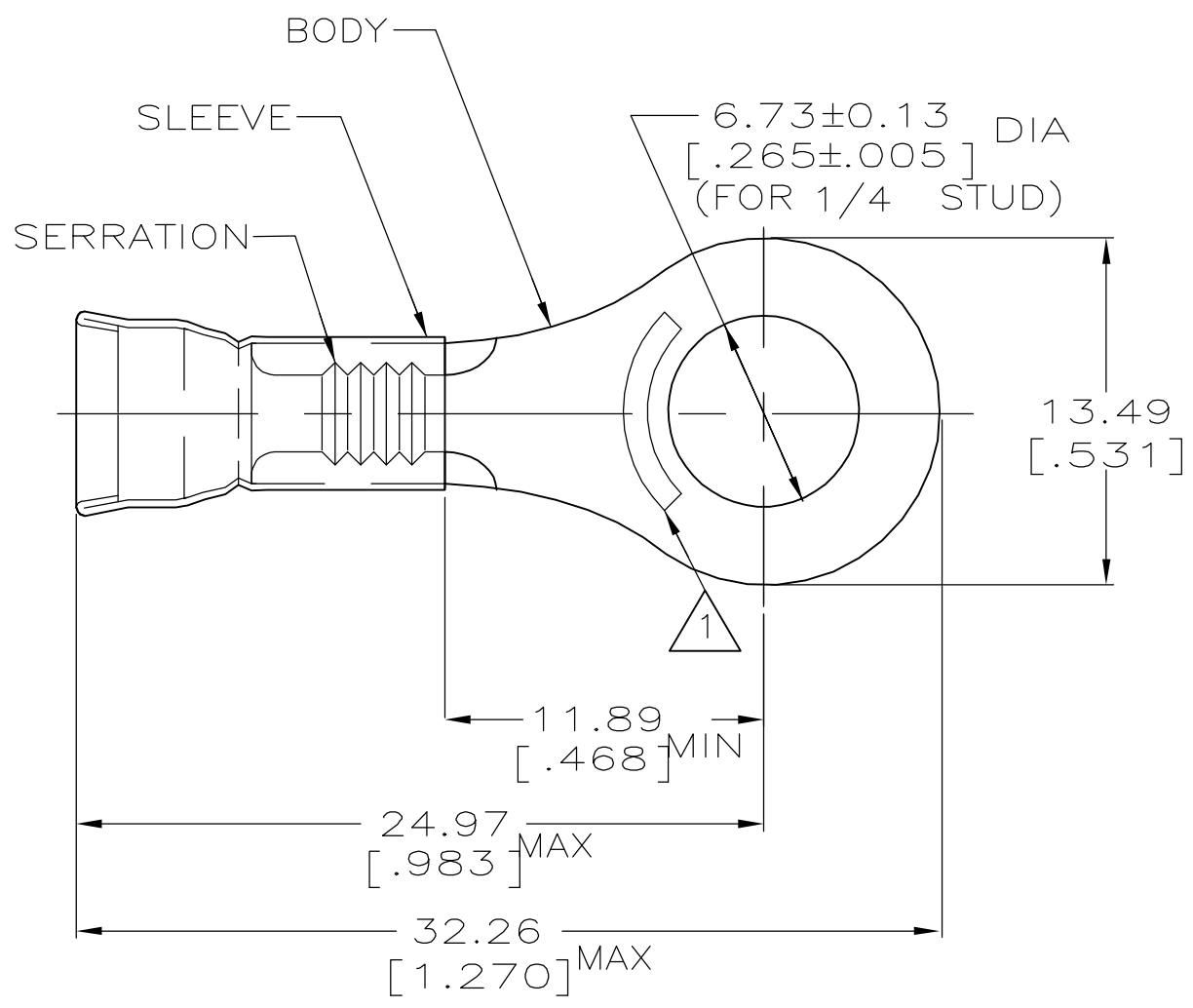

- 1 STAMP AMP 12-10* LOCATE APPROX AS SHOWN
- 2. WIRE INSUL DIA, 3.81-5.84 [.150-.230]
- 3. TONGUE MATL THK, 1.02±0.05 [.040±.002]
- 4 TIN PLATE PER ASTM B-545
- 5 GOLD PLATE PER MIL-G-45204 OVER NICKEL PLATE PER QQ-N-290
- 6 MATERIAL: BODY - CU PER ASTM B152 SLEEVE - CU PER ASTM B152

5	-	LOOSE PIECE	2-31772-2
4	500	LOOSE PIECE	31772
FINISH	QTY	PACKAGE TYPE	PART NO

AMP INCORPORATED CUSTOMER SERVICE SYSTEMS		MAX RECOMMENDED OPERATING TEMPERATURE: 170°C [338°F]	THIS DRAWING IS A CONTROLLED DOCUMENT.		DWN L OLMEDA 23JAN95	Tyco Electronics Corporation Harrisburg, Pa 17105-3608			
FOR ADDITIONAL PRODUCT INFORMATION OR COPIES OF DRAWINGS AND TECHNICAL DOCUMENTS	PRODUCT INFORMATION CENTER 1-800-522-6752	VOLTAGE RATING: -	DIMENSIONS: mm [INCHES]	TOLERANCES UNLESS OTHERWISE SPECIFIED:	CHK M ELLIS 23JAN95	NAME			
FOR APPLICATION TOOLING INFORMATION	TOOLING ASSISTANCE CENTER 1-800-722-1111	CIRCULAR MIL AREA: 2.62-6.64mm² [5,180-13,100] SOLID OR STRANDED		0 PLC ± - 1 PLC ± - 2 PLC ± 0.20 [.008] 3 PLC ± - 4 PLC ± - ANGLES ± -	APVD S BORTNER 23JAN95	PRODUCT SPEC UL486A			
FOR ORDER ENTRY	1-800-526-5142	THIS DRAWING IS A CONTROLLED DOCUMENT FOR AMP INCORPORATED. IT IS SUBJECT TO CHANGE AND THE CONTROLLING ENGINEERING ORGANIZATION SHOULD BE CONTACTED FOR THE LATEST REVISION.	MATERIAL - 6	FINISH SEE TABLE	APPLICATION SPEC -	SIZE A3	CAGE CODE 00779	DRAWING NO C-31772	RESTRICTED TO -
CUSTOMER DRAWING					SCALE 4:1	SHEET 1	OF 1	REV D1	